

Model 793V Series Piezoelectric velocity transducers

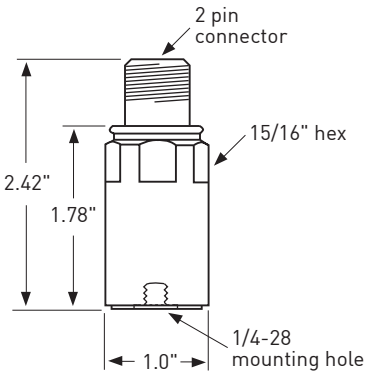

Features:

- Intrinsic safety certified (options for Model 793V, consult factory)
- Industrial ruggedness
- Eliminates distortion caused by high frequency signals
- Corrosion-resistant
- Internally integrated to velocity
- Ultra low-noise electronics for clear signals at very low vibration levels
- Reverse wiring protection



Models	793V	793V-5	Units
Dynamic			
Sensitivity, ±10%, 25°C	100	500	mV/in/sec
Velocity range	50	10	in/sec peak
Amplitude nonlinearity	2.5%	5%	
Frequency response:			
±10%	3.0 - 3,500	8.0 - 3,500	Hz
±3 dB	2.5 - 7,000	5.0 - 7,000	Hz
Resonance frequency, mounted, nom	15	15	kHz
Transverse sensitivity, max.	5% of axial	5% of axial	
Temperature response			
-50°C	-5%	-5%	
+80°C	+3%	+3%	
+120°C	-5%	-5%	
Electrical			
Power requirement: voltage source	18 - 30	18 - 30	VDC
current regulating diode ¹	2 - 10	2 - 10	mA
Electrical noise, equiv. in/sec, nominal:			
Broadband 2.5 Hz to 25 kHz	100	40	µin/sec
Spectral 10 Hz	10	4.0	µin/sec/VHz
100 Hz	1.0	0.4	µin/sec/VHz
1000 Hz	0.2	0.05	µin/sec/VHz
Absolute phase shift, nom. the greater of:	tan ⁻¹ 2/f or 2°	tan ⁻¹ 5/f or 2°	
Output impedance, nominal 4mA supply, the greater of:	5,000 or 200	25,000 or 200	/f Ω
Bias output voltage, nominal	10	10	VDC
Grounding	case isolated, internally shielded	case isolated, internally shielded	
Environmental			
Temperature range	-50 to 120°C	-50 to 120°C	
Vibration limit	250	250	g peak
Shock limit	2,500	2,500	g peak
Electromagnetic sensitivity, equiv. in/sec	25	25	µin/sec/gauss
Sealing	hermetic	hermetic	
Base strain sensitivity	0.0005	0.0005	in/sec/µstrain
Physical			
Weight	145 grams	145 grams	
Case material	316L stainless steel	316L stainless steel	
Mounting	1/4 - 28 tapped hole	1/4 - 28 tapped hole	
Output connector	MIL-C-5015, 2-pin style	MIL-C-5015, 2-pin style	
Connections			
Pin A	signal, power	signal, power	
Pin B	common	common	
Mating connector	R6 (Amphenol 97-3106A-10SL-4S)		
Recommended cable	J9T2		

See notes on the back.

Notes: ¹A maximum current of 6 mA is recommended for operating temperatures in excess of 100 °C.

Options: Intrinsic safety certifications for model 793V; stainless steel flexible hose; temperature sensor (793VT), customer specified sensitivity, low frequency filtering, cable length, connector.

Accessories supplied: SF6 mounting stud, calibration data.

Accessories available: R6SL-J9T2-XX splash-proof cable assembly, magnetic mounting bases, SF8 cementing studs, power supplies, amplifiers, signal conditioners.

Wilcoxon Research Inc
20511 Seneca Meadows Parkway
Germantown, MD 20876
USA

Tel: 301 330 8811
Fax: 301 330 8873
Email: wilcoxon@meggitt.com

www.meggitt.com

MEGGITT
smart engineering for
extreme environments